

VÍDEO DE MONTAJE PASO-A-PASO

STEP-BY-STEP ASSEMBLY VIDEO

▶ youtu.be/8QrAnefiObs



- APERTURA OSCILOBATIENTE CON CIERRE AL MARCO**
TILT & TURN OPENING WITH LOCKING TO FRAME
- APERTURA OSCILOBATIENTE CON MANIOBRA LÓGICA**
TILT & TURN OPENING WITH TILT-BEFORE-TURN SYSTEM
- APERTURA OSCILOBATIENTE CON CIERRE AL INVERSOR**
TILT & TURN OPENING WITH LOCKING TO INVERTER

MANILLAS Y CAJAS DE TRANSMISIÓN
HANDLES & GEARBOXES

▶ stac.es/productos



LA INFORMACIÓN TIENE CARÁCTER ORIENTATIVO Y PUEDE SUFRIR CAMBIOS. STAC NO SE HACE RESPONSABLE DEL USO QUE, EN TODO CASO, ESTÁ DIRIGIDO A PERSONAS CON FORMACIÓN TÉCNICA, QUEDANDO SUJETO A SU RESPONSABILIDAD Y CRITERIO.

THE INFORMATION CONTAINED IS FOR REFERENCE ONLY AND IS SUBJECT TO MODIFICATION. STAC IS NOT RESPONSIBLE FOR ITS USE, WHICH, IN ANY CASE, IS AIMED AT PEOPLE WITH TECHNICAL TRAINING AND IS SUBJECT TO THEIR RESPONSIBILITY AND CRITERIA.

ED. MKT-0202 05.2023

» APERTURA OSCILOBATIENTE CON CIERRE AL MARCO TILT & TURN OPENING WITH LOCKING TO THE WINDOW FRAME

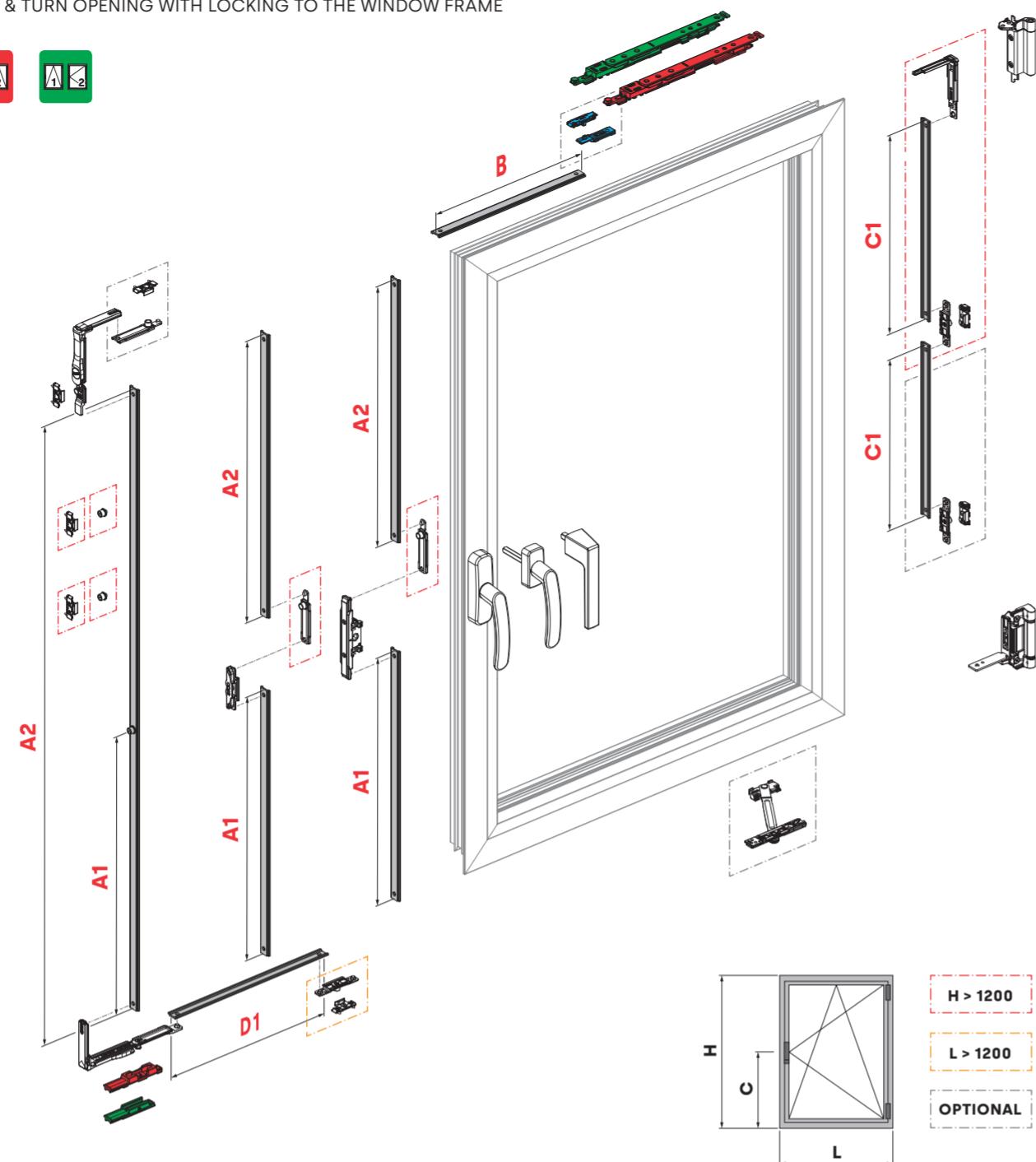

» APERTURA OSCILOBATIENTE CON CIERRE AL INVERSOR TILT & TURN OPENING WITH LOCKING TO THE WINDOW INVERTER

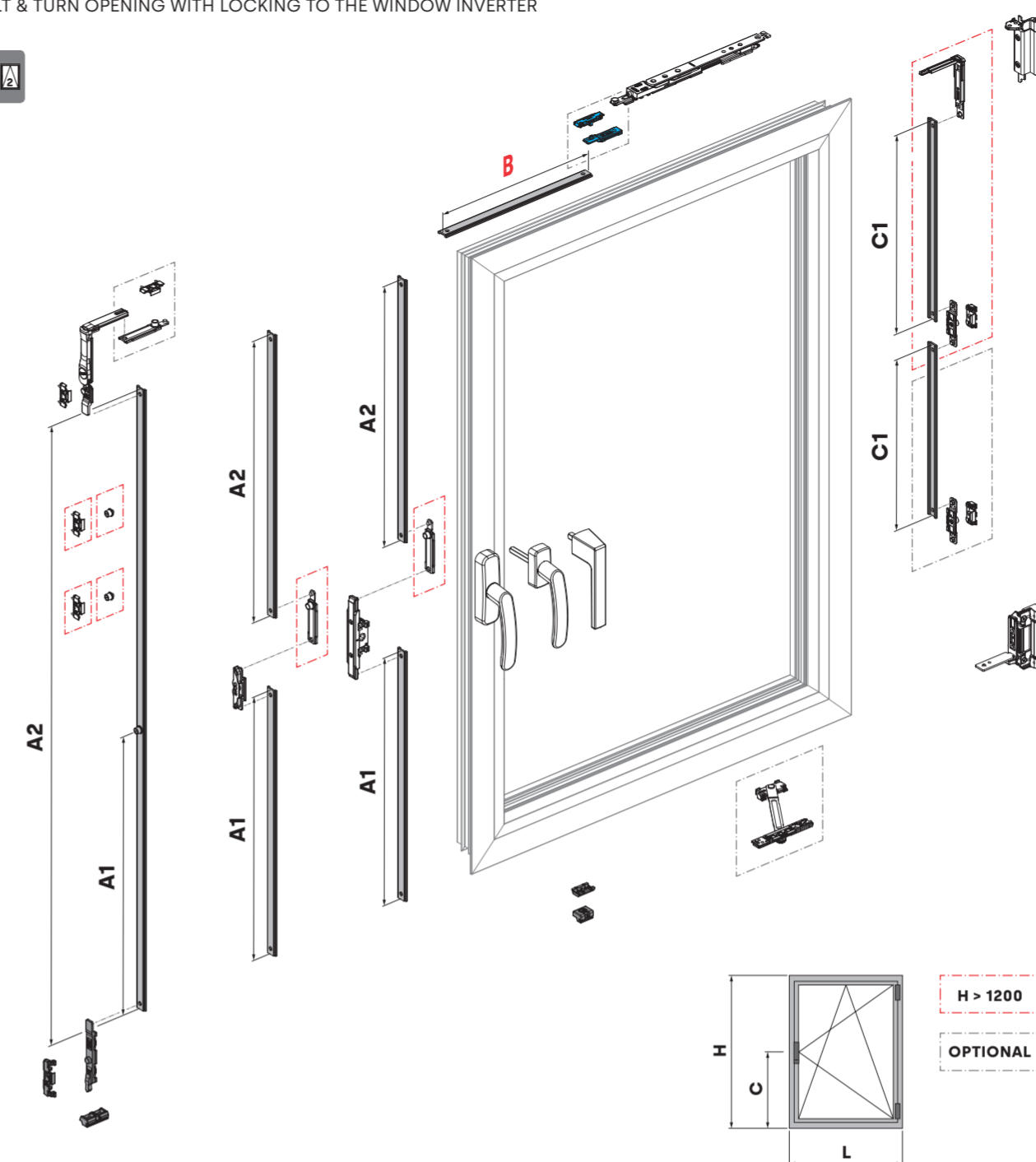

» COMPÁS SUPLEMENTARIO DE CANAL EUROPEO EURO GROOVE SUPPLEMENTARY FRICTION STAY

A130301

L > 1200 mm

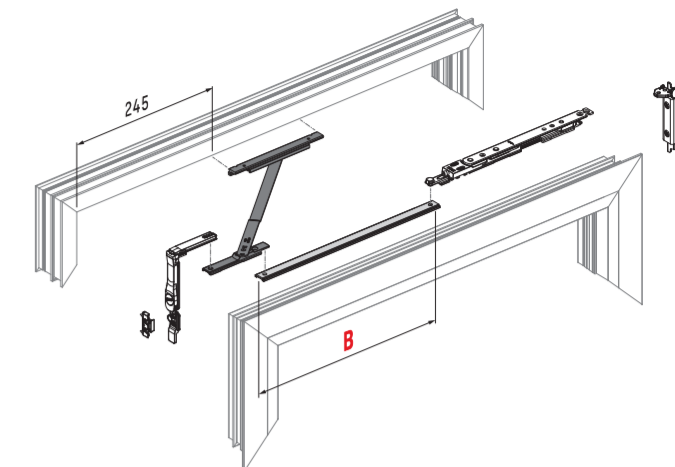

A130301

L > 1200 mm

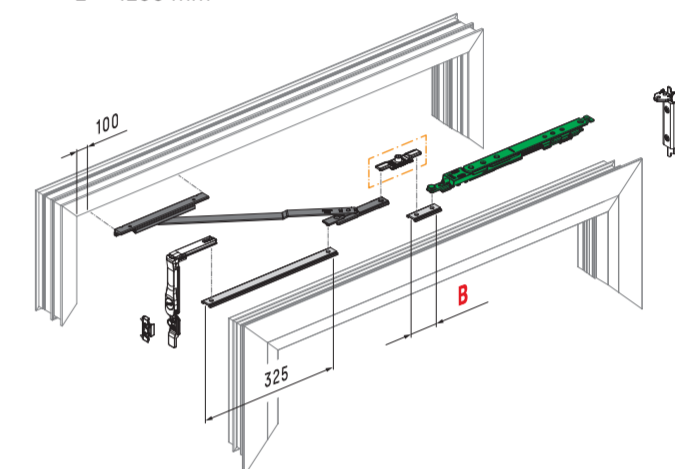

» DESCUENTO DEL HERRAJE HARDWARE DISCOUNT

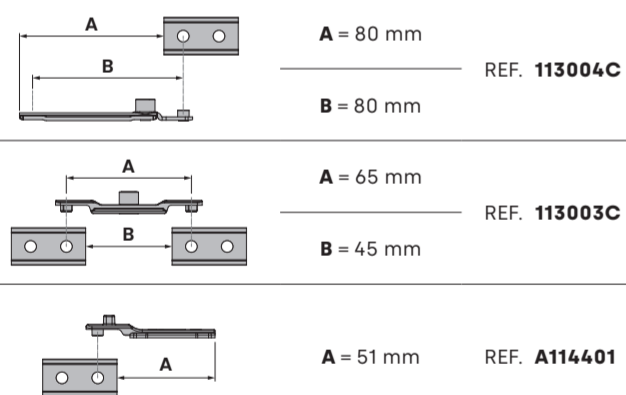

» ELEMENTOS DEL MARCO FRAME PARTS

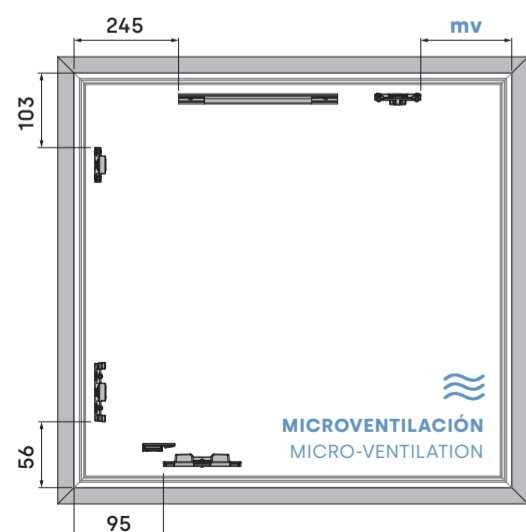

PLANTILLA PARA MONTAJE OSCILOBATIENTE TILT & TURN ASSEMBLY TEMPLATE

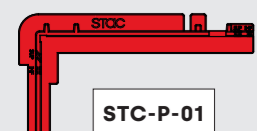

» DESCUENTO DE LOS COMPASES FRICTION STAY DISCOUNT

REFERENCIAS REFERENCES

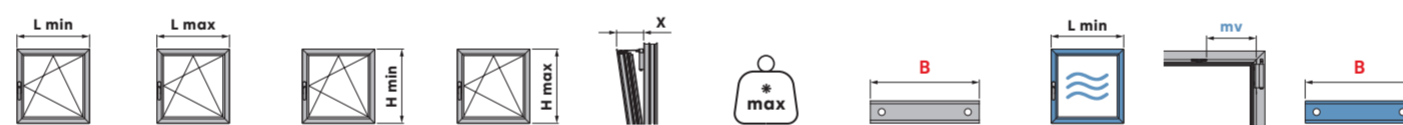

» CLASSIC, SMART, CLX 120, (CLX 160 **)

MICROVENTILACIÓN MICRO-VENTILATION

Model	Type	L min	L max	H min	H max	X	max	B	L min	mv	B	
110309	MICRO	345	700	450	2600	110	120 kg	L - 309	-	435	307	L - 360
B110302	PEQUEÑO SMALL	442	750	500	2600	138	120 kg	L - 373	-	496	371	L - 424
B110301	GRANDE LARGE	570	1200	700	2600	183	120 kg	L - 495	-	618	493	L - 546
B110301 + A130301	GRANDE CON SUPLEMENTARIO LARGE WITH SUPPLEMENTARY	910	1500	700	2600	183	120 kg	L - 595	-	1000	493	L - 646
A110304 + A130301	GRANDE CON SUPLEMENTARIO LARGE WITH SUPPLEMENTARY	1200	-	-	-	-	-	L - 965	325	-	-	-

» CLX 160

T110301	GRANDE CLX CLX LARGE	570	1200	500	2800	135	160 kg	L - 495	-	618	493	L - 546
T110301 + A130301	GRANDE CLX CON SUPLEMENTARIO CLX LARGE WITH SUPPLEMENTARY	910	1500	500	2800	135	160 kg	L - 595	-	1000	493	L - 646
T110304 + A130301	GRANDE CLX CON SUPLEMENTARIO CLX LARGE WITH SUPPLEMENTARY	1200	-	-	-	-	-	L - 965	325	-	-	-

» CH180+

H1213 R3/L3	CH180+ PEQUEÑO CH180+ SMALL	470	1000	550	2600	90	100 kg	L - 432	-	518	406	L - 483
H1213 R4/L4	CH180+ PEQUEÑO CH180+ SMALL	470	1000	550	2600	90	100 kg	L - 432	-	518	406	L - 483
H1213 R1/L1	CH180+ GRANDE CH180+ LARGE	590	1200	650	2600	130	100 kg	L - 516	-	638	490	L - 567
H1213 R2/L2	CH180+ GRANDE CH180+ LARGE	590	1200	650	2600	130	100 kg	L - 516	-	638	490	L - 567
H1213 R1/L1 + A130301	CH180+ CON SUPLEMENTARIO CH180+ WITH SUPPLEMENTARY	930	1500	650	2600	130	100 kg	L - 616	-	1000	490	L - 667
H1213 R2/L2 + A130301	CH180+ CON SUPLEMENTARIO CH180+ WITH SUPPLEMENTARY	1220	-	-	-	-	-	L - 986	325	-	-	-

* VER TABLAS DE PESOS DE CADA BISAGRA SEGÚN LAS DIMENSIONES DE LA VENTANA EN LAS FICHAS TÉCNICAS SEE TABLES OF WEIGHTS ACCORDING TO WINDOW DIMENSIONS IN THE TECHNICAL DATA SHEETS OF EACH HINGE.

** LAS BISAGRAS CLX 160 PUEDEN UTILIZARSE CON COMPASES ESTÁNDAR (MÁXIMO 120 kg) CLX 160 TILT & TURN HINGES CAN BE USED WITH STANDARD FRICTION STAYS (120 kg MAXIMUM)

» DESCUENTO DE LAS FALLEBAS DE TRANSMISIÓN TRANSMISSION ROD DISCOUNT

TRANSMISIÓN TRANSMISSION	CIERRE AL MARCO LOCKING TO WINDOW FRAME				CIERRE AL INVERSOR LOCKING TO WINDOW INVERTER		
	A1	A2	C1	D1	A1	A2	C1
H < 1200 H > 1200	C - 82	H - C - 190 H - C - 270	-	-	C - 150	H - C - 190 H - C - 270	-
H < 1200 H > 1200	C - 116	H - C - 224 H - C - 304	-	-	C - 185	H - C - 224 H - C - 304	-
H < 1200 H > 1200	C - 61	H - 230	-	-	C - 129	H - 298	-
H > 1200	-	-	H / 2 - 205	-	-	-	H / 2 - 205
H > 1800	-	-	H / 3 - 147	-	-	-	H / 3 - 147
L > 1200	-	-	-	L / 2 - 205	-	-	-

» MEDIDAS DE SEGURIDAD DE OBLIGADO CUMPLIMIENTO MANDATORY SAFETY MEASURES

CLASSIC 120 kg

CLX 120 & 160 kg

DIN 7504P 3,5 x 13 mm

